

System Accessories



TL-14D



FBB-150I



PPE

Specifications

Local Lamp : TL-14D (W)

Type	Local Lamp	Local Lamp (Dew drop resist type)
Model Name	TL-14D	TL-14DW
Rating	AC/DC 24V, 9mA	
Lamp	LED	
Operating Temperature Range	-10°C ~ 50°C	
Material	Self Extinguishing Plastic	
Color	Red	
Weight	Approx. 100g	
Applicable Box	Medium size square outlet box : JIS C 8340-5	
Applicable Cover	Medium size square Cover with round hole : JIS C 8340-5	
Made	JAPAN	

Fire Alarm Bell : FBB-150I, -150JW

Type	Alarm Bell	Alarm Bell (Dew drop resist type)
Model Name	FBB-150I	FBB-150JW
Rating	DC 24V, 8mA	
Sound Pressure	≥90 dB (at distance of 1m from the front)	
Operating Temperature Range	-20°C ~ 60°C	
Material	Body : Aluminum alloy die cast Baked Paint finish Mounting Metal : Steel, 1.2mm thickness, Chrome-plated	
Color	Equivalent to Munsell 7.5R3.6/12.8	
Weight	Approx. 465g	Approx. 760g
Made	JAPAN	

Manual Call Point : PPE

Type	P-1 Call Point	P-2 Call Point	P-1 Call Point Dew drop Resist type	P-1 Call Point	P-2 Call Point	P-1 Call Point Dew drop Resist type
Flush / Surface	Flush Mount			Surface Mount		
Model Name	PPE-1	PPE-2	PPE-1W	PPE-1R	PPE-2R	PPE-1RW
Rating	24V, 0.2A, Indoor use					
Operating Temperature Range	-10°C ~ 50°C		-20°C ~ 70°C	-10°C ~ 50°C		-20°C ~ 70°C
Material	Self Extinguishing Plastic					
Color	Red					
Weight	Approx. 180g	Approx. 160g	Approx. 180g	Approx. 320g	Approx. 300g	Approx. 350g
Applicable Box	Medium size square outlet box : JIS C 8336					
Applicable Cover	Medium size square Cover with round hole : JIS C 8336-5					
Made	JAPAN					

HOCHIKI ASIA PACIFIC PTE. LTD.

71 Ubi Road #07-40/41 Oxley Bizhub
Singapore 408732
Tel : 65-6841-9728 Fax : 65-6841-9781
Email : hochiki@singnet.com.sg

HEAD OFFICE

10-43 Kamiosaki 2-Chome. Shinagawa-Ku,
Tokyo 141-8660, Japan
Tel : 81-(3)-3444-4116 Fax : 81-(3)-3444-4167
URL : www.hochiki.co.jp

Hochiki Conventional System

TL-14D

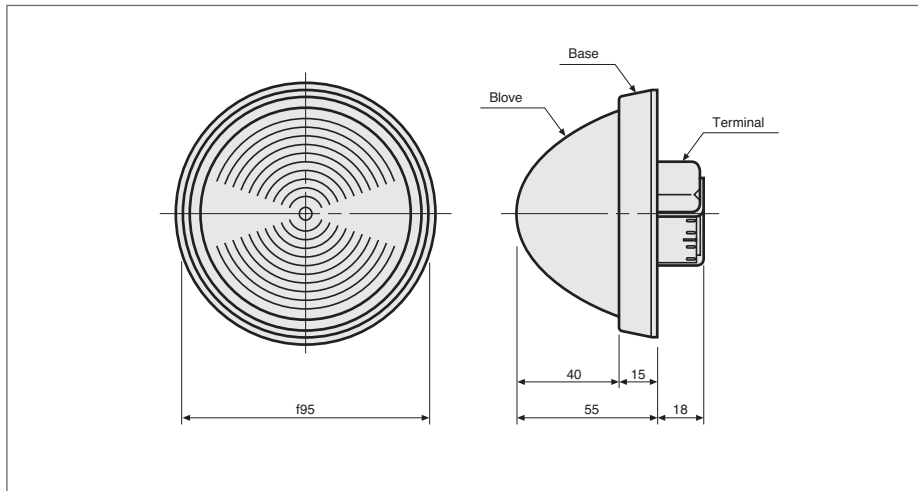

FBB-150I

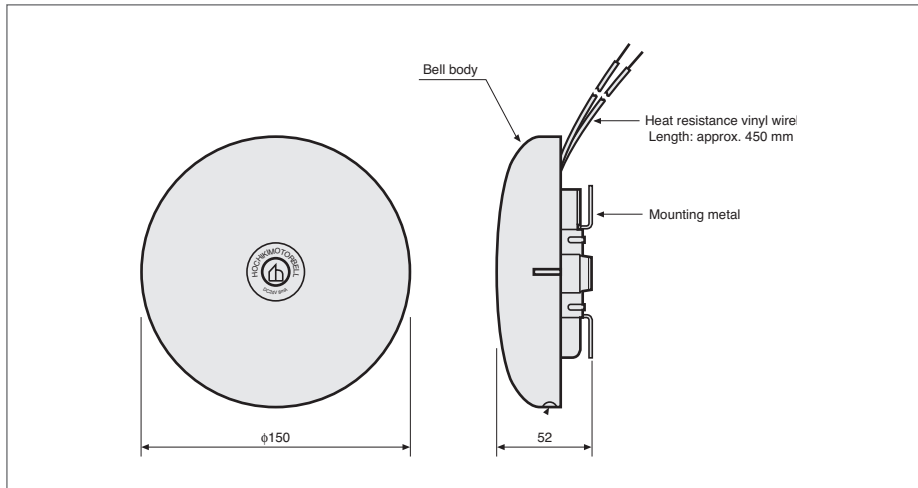

PPE

